

CURRENT TRANSFORMERS
Wound Primary CT
Model CTWH4-75-T100

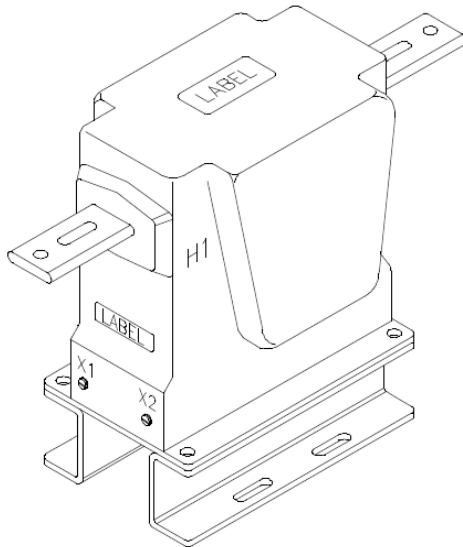

Vacuum cast in polyurethane resin.
Other ratios, secondary currents and dual ratios are available. Refer to factory.

APPLICATION:
Metering and relaying.

FREQUENCY:
50-400 Hz.

MAXIMUM SYSTEM VOLTAGE:
9.52kV, BIL 75kV.

CONTINUOUS THERMAL CURRENT RATING FACTOR:
1.50 at 30oC amb., 1.33 at 55oC. amb.

250:5 and 1000:5-
1.10 at 30oC. amb., 0.85 at 55oC. amb.

1200:5-
1.0 at 30oC. amb., 0.75 at 55oC. amb.

Primary terminals are plated copper bars. See chart next page for sizes. Secondary terminals are brass screws No. 10-32 with one flatwasher, lockwasher.

Approximate weight 42 lbs.

CATALOG NUMBER	CURRENT RATIO	RELAY CLASS	ANSI METERING CLASS AT 60HZ					* THERMAL CURRENT RATING 1 SECOND RMS AMPS
			BO.1	BO.2	BO.5	BO.9	B1.8	
CTWH4-75-T100-050	5:5	T100	0.3	0.3	0.3	0.3	0.3	470
CTWH4-75-T100-100	10:5	T100	0.3	0.3	0.3	0.3	0.3	900
CTWH4-75-T100-150	15:5	T100	0.3	0.3	0.3	0.3	0.3	1600
CTWH4-75-T100-200	20:5	T100	0.3	0.3	0.3	0.3	0.3	1900
CTWH4-75-T100-250	25:5	T100	0.3	0.3	0.3	0.3	0.3	2600
CTWH4-75-T100-300	30:5	T100	0.3	0.3	0.3	0.3	0.3	2900
CTWH4-75-T100-400	40:5	T100	0.3	0.3	0.3	0.3	0.3	3800
CTWH4-75-T100-500	50:5	T100	0.3	0.3	0.3	0.3	0.3	4700
CTWH4-75-T100-750	75:5	T100	0.3	0.3	0.3	0.3	0.3	5900
CTWH4-75-T100-101	100:5	T100	0.3	0.3	0.3	0.3	0.3	8600
CTWH4-75-T100-151	150:5	T100	0.3	0.3	0.3	0.3	0.3	12900
CTWH4-75-T100-201	200:5	T100	0.3	0.3	0.3	0.3	0.3	17200
CTWH4-75-T100-251	250:5	T100	0.3	0.3	0.3	0.3	0.3	17200
CTWH4-75-T100-301	300:5	T100	0.3	0.3	0.3	0.3	0.3	34500
CTWH4-75-T100-401	400:5	T100	0.3	0.3	0.3	0.3	0.3	34500
CTWH4-75-T100-601	600:5	T100	0.3	0.3	0.3	0.3	0.3	66200
CTWH4-75-T100-801	800:5	T100	0.3	0.3	0.3	0.3	0.3	66200
CTWH4-75-T100-102	1000:5	T100	0.3	0.3	0.3	0.3	0.3	66200
CTWH4-75-T100-122	1200:5	T100	0.3	0.3	0.3	0.3	0.3	66200

*With a burden of BO.1 or greater connected to the secondary.

Model CTWH4--75--T100 Wound Primary CT

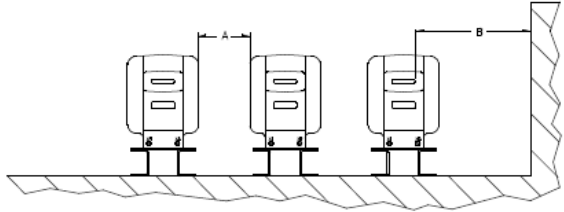
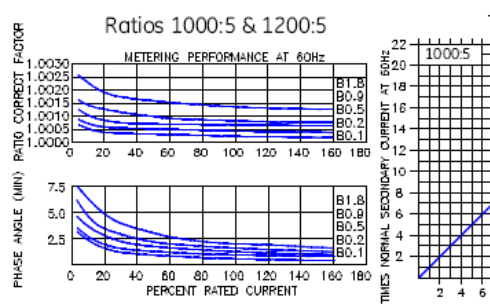
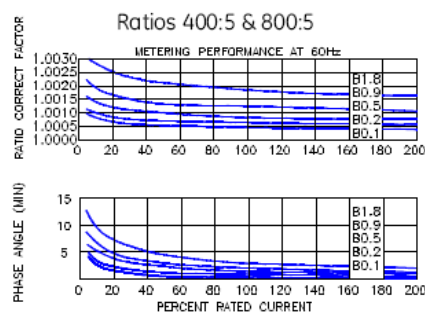
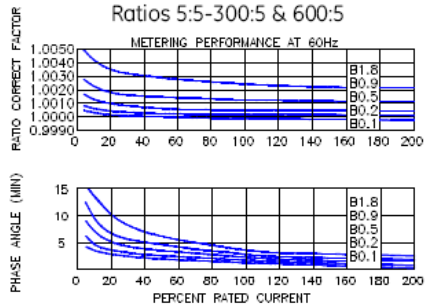

RECOMMENDED MINIMUM SPACINGS

A = Unit to Unit = 1.00" minimum.
 B = HV to Ground in Air = 4.50" minimum.

Recommended spacing are for guidance only. User needs to set appropriate values to assure performance for high potential test, impulse test, high humidity, partial discharge, high altitude, and other considerations like configuration.

PRIMARY CURRENT	DIMENSIONS	
	A	B
5 TO 200A	0.25	1.50
250 TO 1200A	0.38	2.00

